

Assembly Instructions for PMA-4031 Flat Panel Wall Mount

Thank you for choosing our PMA-4031 flat panel wall mount. This product is designed to hold 50"-102" Flat Panel LCD or Plasma Displays weighing up to 330 lbs/150 kg. It will allow you to effortlessly tilt the display from +15° to -15°.

Safety Warning: If you do not understand these directions, or have any doubts about the safety of the installation, please call a qualified contractor. Check carefully to make sure there are no missing or defective parts. Never use defective parts. Improper installation may cause damage or serious injury. Do not use this product for any purpose that is not explicitly specified in this manual. We can not be liable for damage or injury caused by incorrect mounting, incorrect assembly, or incorrect use.

Note: The supplied wall mounting hardware is not for steel stud walls or old cinder block walls. If you are uncertain about the nature of your wall, consult an installation contractor. We makes every effort to assure all necessary television mounting hardware is included. If the hardware you need is not included please consult your local hardware store.

Required Tools: 3/16 drill bit, 1/2" Masonry Bit for brick concrete or concrete block installations, wrench or socket set, Phillips screw driver and socket set.

Supplied Parts

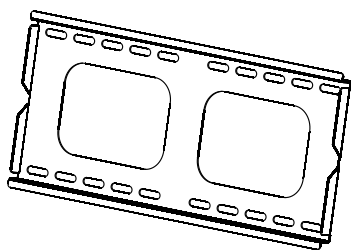

(2) Wall Plate-a

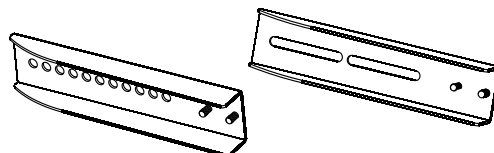

(2) Monitor Bracket Extensions-b

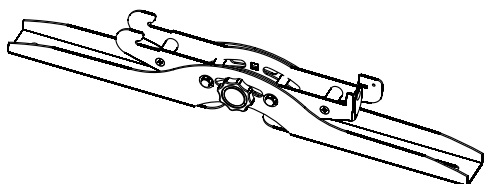

(1) Right Monitor Bracket-c

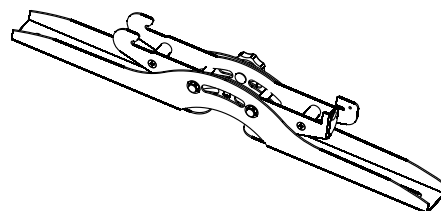

(1) Left Monitor Bracket-d

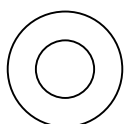

(8) Metal Washer-e



(8) Flange Nut-f

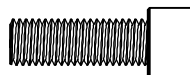

(2) Safety Bolt-g



(1) Allen Key-h



(8) Lag Bolt-i

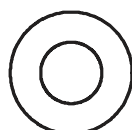

(8) Lag Bolt Washer-j



(8) Concrete Anchor-k

TV Mounting Hardware:



(4)M4x12 Bolt-l

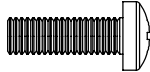

(4)M5x12 Bolt-m

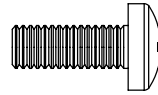

(4)M6x12 Bolt-n

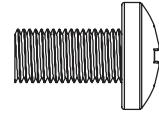

(4)M8x16 Bolt-o



(4)M4x30 Bolt-p



(4)M5x30 Bolt-q

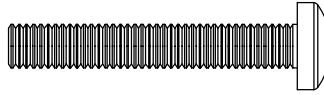

(4)M6x35 Bolt-r

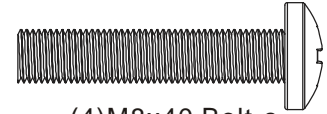

(4)M8x40 Bolt-s



(4)M4 Lock Washer-t



(4)M5 Lock Washer-u



(4)M6 Lock Washer-v

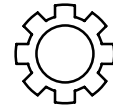

(4)M8 Lock Washer-w

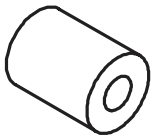

(4)M4/M5 Space-x

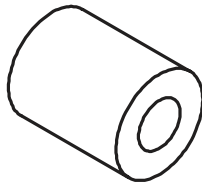

(4)M6/M8 Space-y

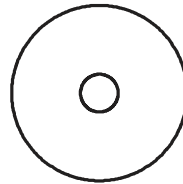

(8)M4/M5 Washer-z

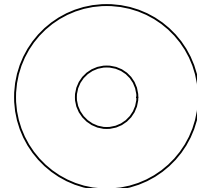

(4)M6/M8 Washer-A

Step 1: Configure the Monitor Brackets

Determine if you need to install the Monitor Bracket Extensions (b) onto the Monitor Brackets (c,d) by placing a Monitor Bracket on the back of the TV. If the hole pattern on the back of the TV falls within the vertical reach of the Monitor Bracket, you do not need to install the Monitor Bracket Extensions. Proceed to Step 2.

Note: Both Monitor Bracket Extensions must either be used for each arm or none should be used at all

To install the Monitor Bracket Extensions (b) place the threaded stud portion through the Monitor Bracket (c,d). Slide a Metal Washer (e) onto the threaded stud, and secure the Monitor Bracket Extension by threading and tightening a Flange Nut (f) onto each threaded stud. The Monitor Bracket Extensions can be adjusted to the correct height. The Diagrams below show the maximum extension. Both threaded studs on each Monitor Bracket Extension must pass through the Monitor Bracket to ensure a safe installation!

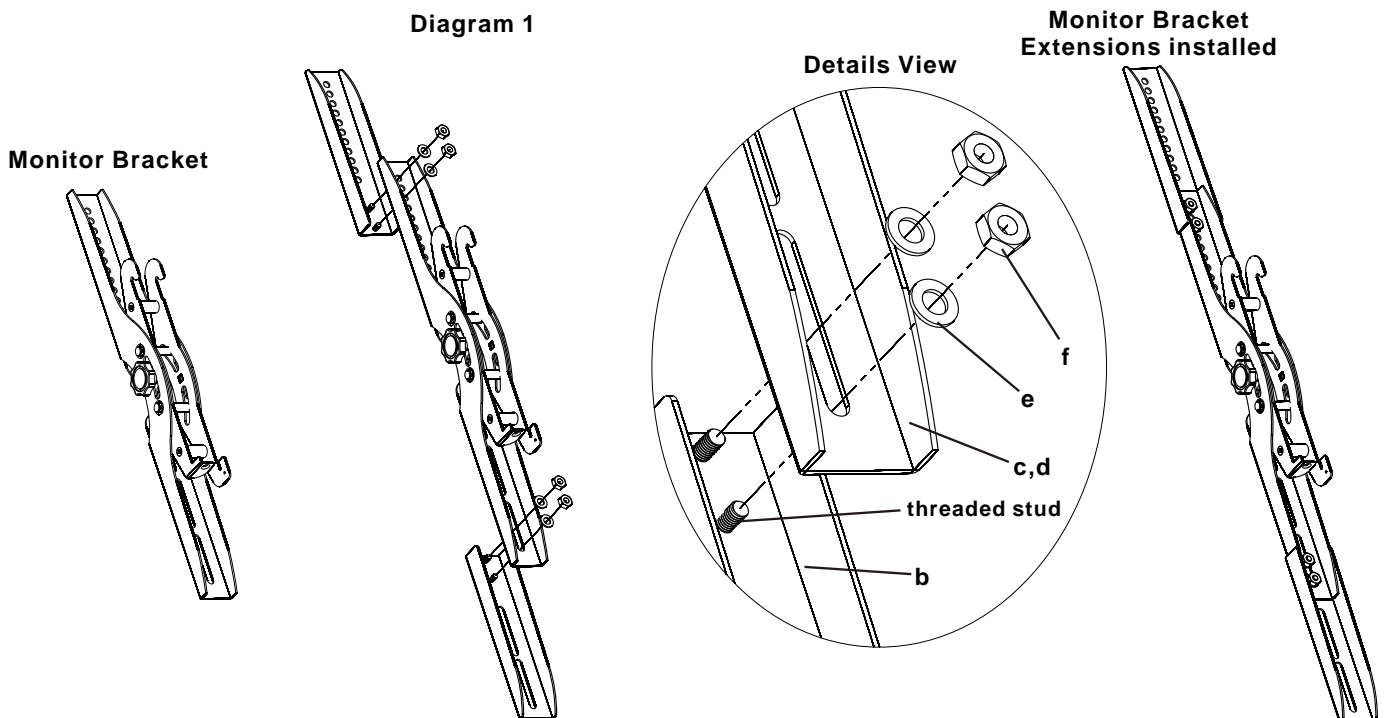

Step 2: Install Monitor Brackets to a television with a flat back

Note: For televisions with a curved back, or an obstruction near the threaded insert see Step 3.

First, determine the diameter of the Bolt (l,m,n,o) your TV requires by hand threading them into the threaded insert on the back of the TV. If you encounter any resistance stop immediately! Once you have determined the correct diameter, see the appropriate Diagram below. You will thread the Bolt through the appropriate Lock Washer (t,u,v,w), the corresponding Washer (z,aa), the Monitor Bracket (c,d) or the Monitor Bracket Extension (b), and finally into the TV. Make sure the Monitor Brackets are vertically centered and level with each other. See the appropriate Diagram below.

M4 Diameter Bolt

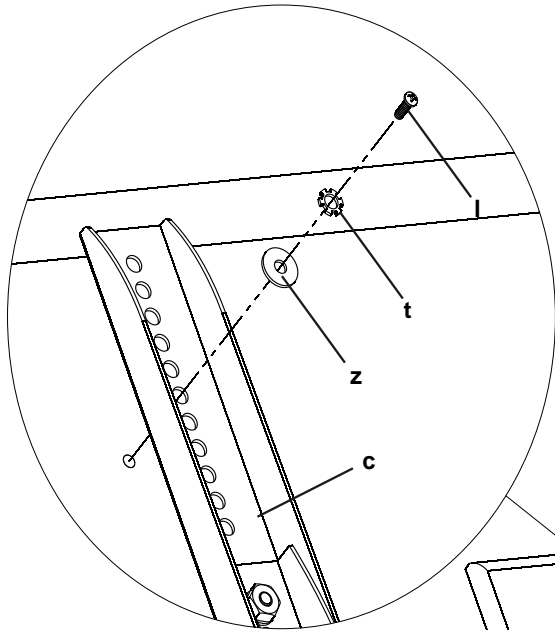

M6 Diameter Bolt

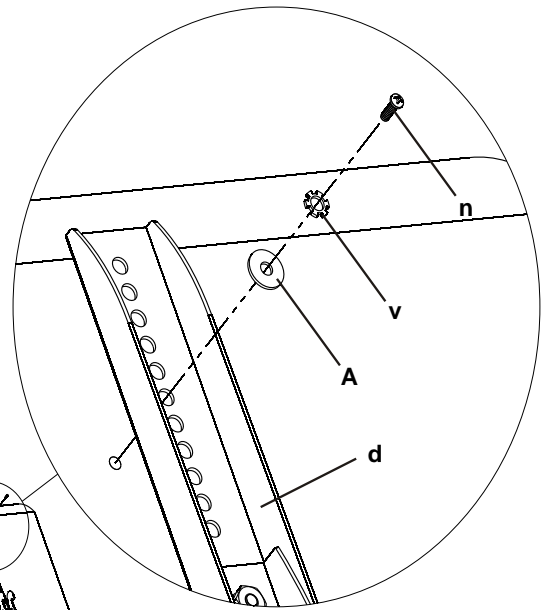
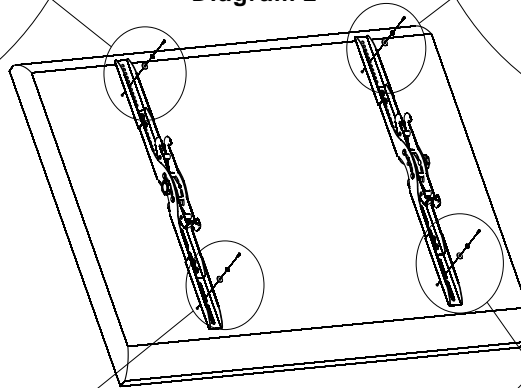
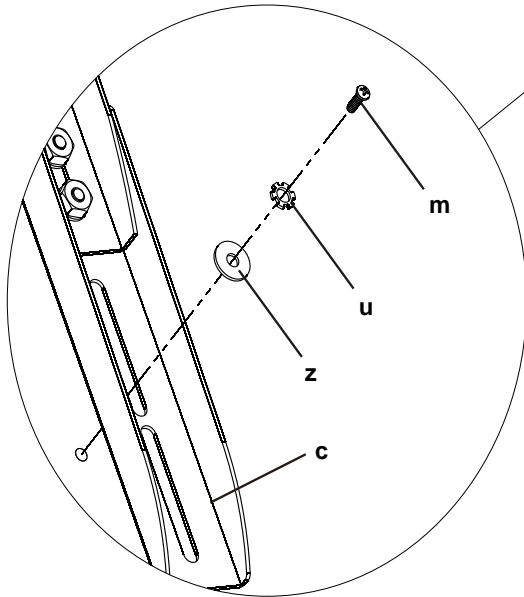

Diagram 2



M5 Diameter Bolt



M8 Diameter Bolt

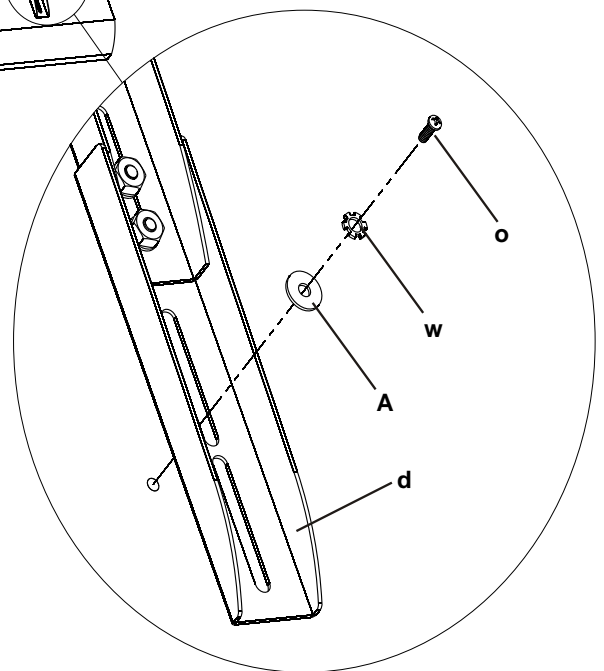

Note: After completing this step, go to Step 4.

Step 3: Install Monitor Brackets to a television with a curved back or an obstruction near the threaded insert

First, determine the diameter of the Bolt (p,q,r,s) your TV requires by hand threading them into the threaded insert on the back of the TV. If you encounter any resistance stop immediately! Once you have determined the correct diameter, see the appropriate Diagram below. You will thread the Bolt through the appropriate Lock Washer (t,u,v,w), the corresponding Washer (z,aa), the Monitor Bracket (c,d) or Monitor Bracket Extension (b), a second Washer (z - M4/M5 diameters only), a Spacer (x,y) and finally into the TV. Make sure the Monitor Brackets are vertically centered and level with each other. See the appropriate Diagram below.

M4 Diameter Bolt

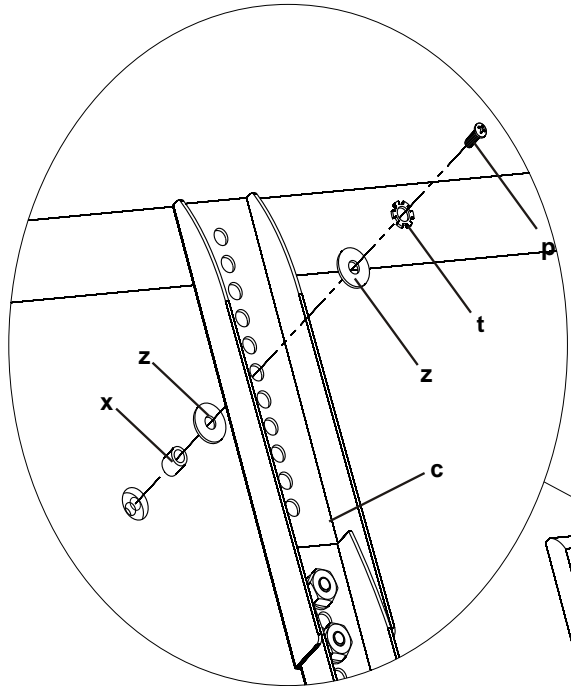

M6 Diameter Bolt

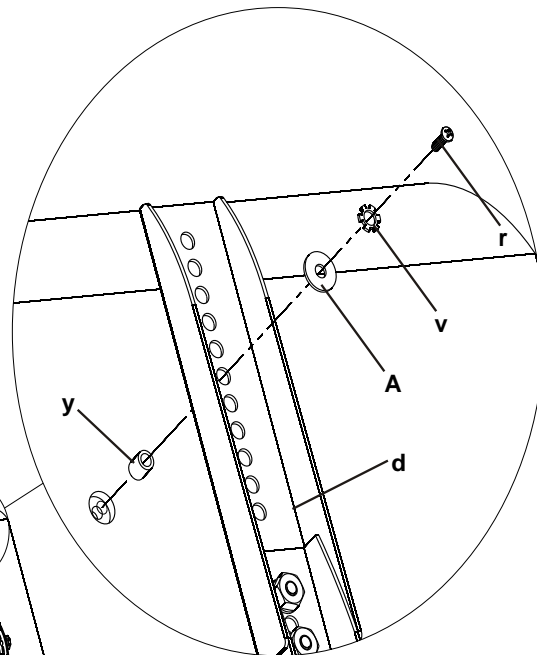
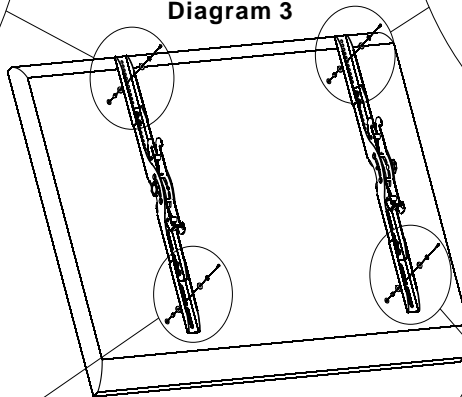
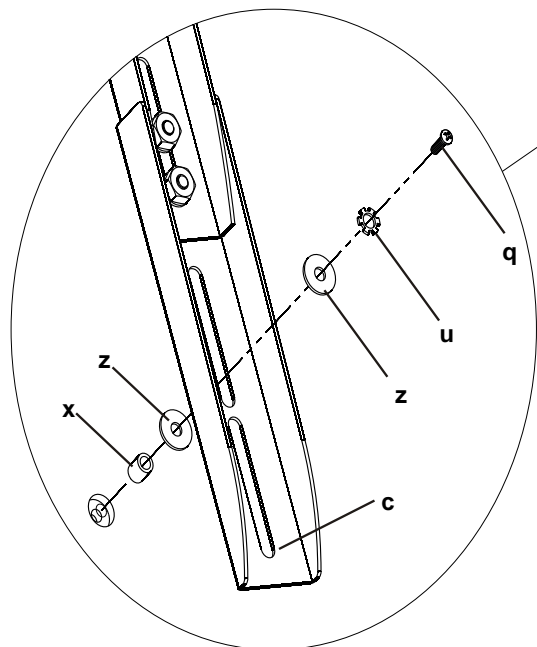

Diagram 3



M5 Diameter Bolt



M8 Diameter Bolt

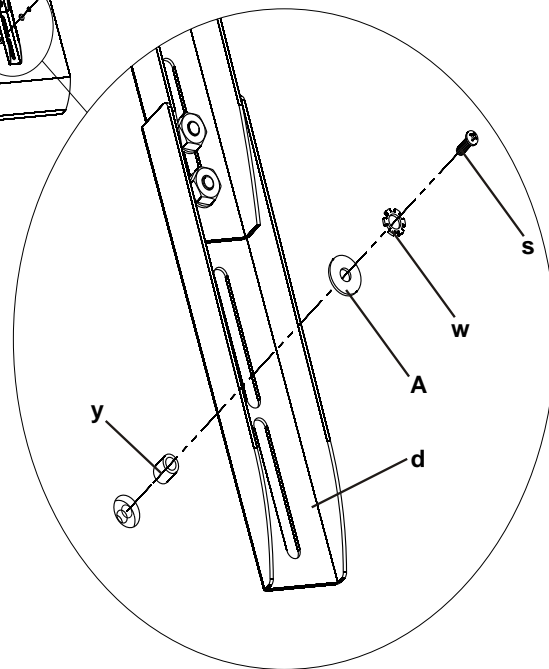

Step 4: Install Two Wall Plates on wall.

Wood Stud mounting:

Each of the Wall Plate(a) **must be mounted to two wood studs, each at least 12" apart**. Use a high quality stud sensor to locate two adjacent studs. It is a good idea to verify where the studs are located with an awl or thin nail shown in Diagram 4a. Pre-drill a 2.5" deep hole at the desired height in each stud using a 3/16" drill bit. Make sure these holes are in the centre area of the studs and level with each other. Use the Wall Plate as a template to mark the location of the second hole in each stud. Drill 2.5" deep holes using the 3/16" drill bit in each marked location. Attach the Wall Plate to the wall using Lag Bolts (i) and Lag Bolt Washers (j). Use two Lag Bolts and two Lag Bolt Washers per stud.

Brick, Solid Concrete and Concrete Block mounting:

Use the each of Wall Plate (a) as a template to mark four hole locations on the wall. Two in the top row of slots and two more in the bottom row. Make sure these holes are level and there is at least 6" between any two holes. Carefully pre-drill these holes with a 1/2" masonry bit to avoid chipping or breaking. Holes should be at least 2.5" in depth. Insert a Concrete Anchor (k) into each of these holes. Make sure the anchor is seated completely flush with the concrete surface, even if there is a layer of drywall or other material in front. Attach the Wall Plate to the wall using four Lag Bolts (i) and four Lag Bolt Washers (j). Drill into the brick or block, never the mortar!

Diagram 4a

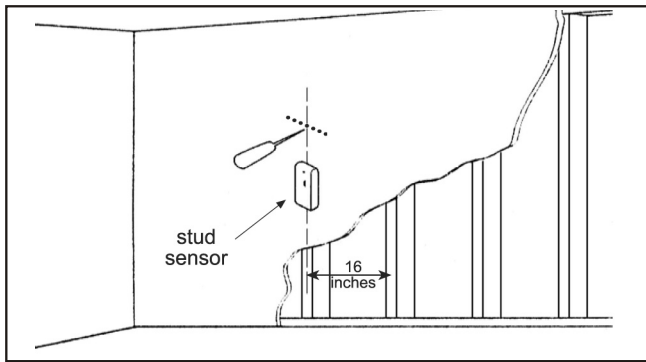
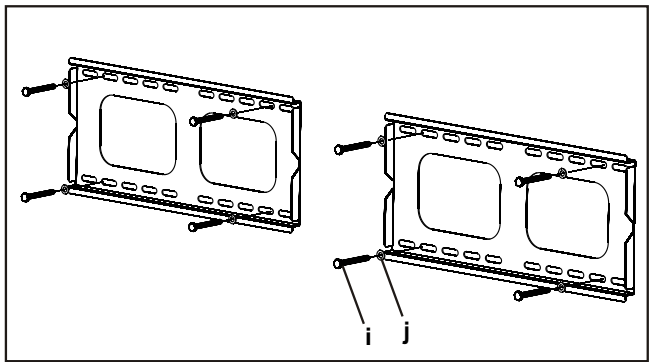

Diagram 4b



Step 5: Hang the TV onto the Wall Plate

Warning: Some televisions may require 2 people to lift! We are not responsible for personal injury or product damage.

Hang the TV onto the Wall Plate: First hook the Monitor Brackets (c,d) over the top of the Wall Plate(a), then let the bottom of the Monitor Brackets rotate in under the bottom of the Wall Plate as shown in diagram 5a. Tighten Safety Bolts (g) with the Allen Key (h) so that they sit behind the bottom tab on the Wall Plate as shown in the Detailed View of Diagram 5b. Finally set tension of the knobs on the Monitor Brackets and you are free to adjust your new flat panel TV without having to re-tighten the knobs.

Diagram 5a

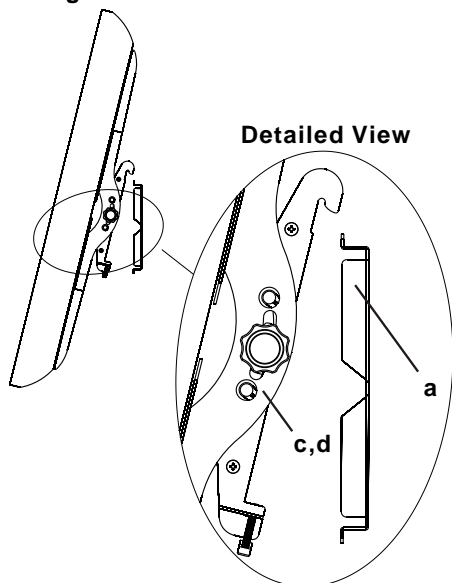

Diagram 5b

